

S8600B,C,H,M; S8610B,C,H,M; S8670D,E,J,K Intermittent Pilot Gas Ignition Control

INSTALLATION INSTRUCTIONS

APPLICATION

The 8600 family of ignition controls provide ignition sequence, flame monitoring and safety shutoff for intermittent pilot gas fired heating appliances. These controls provide flame sense and operating sequences suitable for the application.

Table 1 describes the main features of each available model.

Table 1. Intermittent Pilot Ignition Models.

Model	Igniter-Sensor Type	Valve Current Rating @ 24 Vac	Prepurge Timing	Trial for Pilot Ignition	Ignition Sequence Type	Ignition Sequence Description ^a
S8600B	Separate ^b	1.0 A Pilot and 1.0 A Main	None	15 or 90 seconds, as ordered	Lockout	Spark and pilot gas ON until lightoff or trial for ignition ends. If pilot fails to light, pilot gas and spark OFF (100% shutoff), and lockout. Cycle "Call for Heat" to restart ignition sequence.
S8600C	Separate	1.0 A Pilot and 1.0 A Main	None	15 or 90 seconds, as ordered	Continuous Retry	Spark and pilot gas ON until lightoff or trial for ignition ends. If pilot fails to light, pilot gas and spark OFF (100% shutoff). After 5 minute delay, a new trial for ignition is initiated. This sequence continues until lightoff or "Call for Heat" is removed.
S8600H	Combination ^c	1.0 A Pilot and 1.0 A Main	None	15 or 90 seconds, as ordered	Lockout	Spark and pilot gas ON until lightoff or trial for ignition ends. If pilot fails to light, pilot gas and spark OFF (100% shutoff), and lockout. Cycle "Call for Heat" to restart ignition sequence.
S8600M	Combination	1.0 A Pilot and 1.0 A Main	None	15 or 90 seconds, as ordered	Continuous Retry	Spark and pilot gas ON until lightoff or trial for ignition ends. If pilot fails to light, pilot gas and spark OFF (100% shutoff). After 5 minute delay, a new trial for ignition is initiated. This sequence continues until lightoff or "Call for Heat" is removed.
S8610B	Separate	1.0 A Pilot and 2.0 A Main	None	15 or 90 seconds, as ordered	Lockout	Spark and pilot gas ON until lightoff or trial for ignition ends. If pilot fails to light, pilot gas and spark OFF (100% shutoff), and lockout. Cycle "Call for Heat" to restart ignition sequence.
S8610C	Separate	1.0 A Pilot and 2.0 A Main	None	15 or 90 seconds, as ordered	Continuous Retry	Spark and pilot gas ON until lightoff or trial for ignition ends. If pilot fails to light, pilot gas and spark OFF (100% shutoff). After 5 minute delay, a new trial for ignition is initiated. This sequence continues until lightoff or "Call for Heat" is removed.
S8610H	Combination	1.0 A Pilot and 2.0 A Main	None	15 or 90 seconds, as ordered	Lockout	Spark and pilot gas ON until lightoff or trial for ignition ends. If pilot fails to light, pilot gas and spark OFF (100% shutoff), and lockout. Cycle "Call for Heat" to restart ignition sequence.



Table 1. Intermittent Pilot Ignition Models. (Continued)

Model	Igniter-Sensor Type	Valve Current Rating @ 24 Vac	Prepurge Timing	Trial for Pilot Ignition	Ignition Sequence Type	Ignition Sequence Description ^a
S8610M	Separate	1.0 A Pilot and 2.0 A Main	None	15 or 90 seconds, as ordered	Continuous Retry	Spark and pilot gas ON until lightoff or trial for ignition ends. If pilot fails to light, pilot gas and spark OFF (100% shutoff). After 5 minute delay, a new trial for ignition is initiated. This sequence continues until lightoff or "Call for Heat" is removed.
S8670D	Combination	1.0 A Pilot and 2.0 A Main	30 seconds	15 or 90 seconds, as ordered	Lockout	After prepurge, spark and pilot gas ON until lightoff or trial for ignition ends. If pilot fails to light, pilot gas and spark OFF (100% shutoff), and lockout. Cycle "Call for Heat" to restart ignition sequence.
S8670E	Combination	1.0 A Pilot and 2.0 A Main	30 seconds	15 or 90 seconds, as ordered	Continuous Retry	After prepurge, spark and pilot gas ON until lightoff or trial for ignition ends. If pilot fails to light, pilot gas and spark OFF (100% shutoff). After 5 minute delay, a new trial for ignition is initiated. This sequence continues until lightoff or "Call for Heat" is removed.
S8670J	Separate	1.0 A Pilot and 2.0 A Main	30 seconds	15 or 90 seconds, as ordered	Lockout	After prepurge, spark and pilot gas ON until lightoff or trial for ignition ends. If pilot fails to light, pilot gas and spark OFF (100% shutoff), and lockout. Cycle "Call for Heat" to restart ignition sequence.
S8670K	Separate	1.0 A Pilot and 2.0 A Main	30 seconds	15 or 90 seconds, as ordered	Continuous Retry	After prepurge, spark and pilot gas ON until lightoff or trial for ignition ends. If pilot fails to light, pilot gas and spark OFF (100% shutoff). After 5 minute delay, a new trial for ignition is initiated. This sequence continues until lightoff or "Call for Heat" is removed.

^a If established flame is lost, all models restart ignition trial.

^b Separate: two rod; remote flame sensing.

^c Combination: one rod; local flame sensing.

All models provide:

- Natural or LP gas.
- Pilot burner ignition using a high voltage spark.
- Flame rectification circuit to monitor flame presence.
- Monitoring of 24 Vac, pilot, and main gas valve.
- Two LED indicators for flame presence/strength and system status/errors.
- EnviraCOM™ communication protocol for system diagnostics.
- Optional: Alarm Output dry contacts (Lockout models Only).

SPECIFICATIONS

Control Voltage: 24V (18-30 Vac) 50/60 Hz
Current Draw: 0.1 A plus valve load @ 24Vac
Trial for Ignition: 15 or 90 seconds (depends on model)
Prepurge: See Table 1.

Ignition Sequence: See Table 1.

Retry Delay: 5 minutes (C, M, E, and K models only)

Flame Failure Response Time: 2 seconds maximum

LEDs: Two LEDs provide the following:

- The Status LED (green) provides system status and error codes.
- The Flame LED (yellow) indicates flame presence and flame strength.

Gas Control: Honeywell models VR8204 and VR8304

Operating Temperature:

Minimum ambient temperature rating is -40°F (-40°C).

Maximum ambient rating for S8600 used with 1.0A main valve is 175°F (79°C).

Maximum ambient rating for S8610 and S8670 used with 2.0A main valve is 165°F (74°C).

Relative humidity: 0% to 95% noncondensing

PLANNING THE INSTALLATION

WARNING

Fire or Explosion Hazard.

Can cause severe injury, death or property damage.

1. Plan the installation as outlined below.
2. Plan for frequent maintenance as described in the Maintenance section.

Intermittent pilot systems are used on a wide variety of central heating equipment and on heating appliances such as commercial cookers, agricultural equipment, industrial heating equipment and pool heaters. Some of these applications may make heavy demands on the controls, either because of frequent cycling, or because of moisture, corrosive chemicals, dust or excessive heat in the environment. In these situations, special steps may be required to prevent nuisance shutdowns and premature control failure. These applications require special Honeywell review; contact your Honeywell Sales Representative for assistance.

Review the following conditions that can apply to your specific installation and take the precautionary steps suggested.

Frequent Cycling

These controls are designed for use on appliances that typically cycle three to four times an hour only during the heating season. In year-round applications with greater cycling rates, the control can wear out more quickly; perform a monthly checkout.

Water or Steam Cleaning

If the control gets wet, replace it. If the appliance is likely to be cleaned with water or steam, protect (cover) the controls and wiring from water or steam flow. Mount the controls high enough above the bottom of the cabinet so they do not get wet during normal cleaning procedures. Use a NEMA 4 enclosure for the ignition control.

High Humidity or Dripping Water

Dripping water can cause the control to fail. Never install an appliance where water can drip on the controls.

In addition, high ambient humidity can damage the control.

If the appliance is in a humid atmosphere, make sure air circulation around the controls is adequate to prevent condensation. Also, regularly check out the system. A NEMA 4 enclosure is recommended for the ignition module.

Corrosive Chemicals

Corrosive chemicals can attack the module and gas control, eventually causing a failure. If chemicals are used for routine cleaning, make sure they do not reach the controls. Where chemicals are suspended in air, as in some industrial or agricultural applications, use a NEMA 4 enclosure for the ignition module.

Dust or Grease Accumulation

Heavy accumulations of dust or grease can cause controls to malfunction. Where dust or grease can be a problem, provide covers for the module and the gas control to limit contamination. A NEMA 4 enclosure is recommended for the ignition module.

Heat

Excessively high temperatures can damage controls. Make sure the maximum ambient temperature at the control does not exceed the rating of the control. If the appliance operates at very high temperatures, use insulation, shielding, and air circulation, as necessary, to protect the controls. Proper insulation or shielding should be provided by the appliance manufacturer; verify proper air circulation is maintained when the appliance is installed.

INSTALLATION

When Installing This Product...

1. Read these instructions carefully. Failure to follow them could damage the product or cause a hazardous condition.
2. Check the ratings given in these instructions to make sure the control is suitable for your application.
3. Installer must be a trained, experienced service technician.
4. After installation is complete, check out operation as provided in these instructions.

WARNING

Fire or Explosion Hazard.

Can cause severe injury, death or property damage.

1. The module can malfunction if it gets wet, leading to accumulation of explosive gas.
 - Never install where water can flood, drip or condense on the module.
 - Never try to use a module that has been wet—replace it.
2. Liquefied petroleum (LP) gas is heavier than air and will not naturally vent upward.
 - Do not operate electric switches, lights, or appliances until you are sure the appliance area is free of gas.

WARNING

Electrical Shock Hazard.

Can cause severe injury, death or property damage.

Disconnect power supply before beginning wiring or making wiring connections to prevent electrical shock or equipment damage.

CAUTION

1. If a new gas control is to be installed, turn off the gas supply before starting installation. Conduct a Gas Leak Test according to the gas control manufacturer instructions after the gas control is installed.
2. Wiring errors can cause improper appliance operation and dangerous conditions such as bypassing safety features.

CAUTION

Equipment Damage Hazard.

Water can cause equipment damage or malfunction.

If the module must be mounted near water or moisture, provide suitable waterproof enclosure.

Maintenance Requirements in Severe Environments

Regular preventive maintenance is important in any application.

WARNING

Fire or Explosion Hazard.

May cause severe injury, death or property damage.

Do not attempt to take the module apart or to clean it. Improper reassembly and cleaning may cause unreliable operation.

Maintenance frequency must be determined individually for each application. Some considerations are:

- Cycling frequency. Appliances that may cycle more than 20,000 times annually should be checked monthly.
- Intermittent use. Appliances that are used seasonally should be checked before shutdown and again before the next use.

- Consequence of unexpected shutdown. Where the cost of an unexpected shutdown would be high, the system should be checked more often.
- Dusty, wet, or corrosive environment. Since these environments can cause the modules to deteriorate more rapidly, the system should be checked more often.

Any module should be replaced if it does not perform properly on checkout or troubleshooting. In addition, replace any module if it is wet or looks like it has ever been wet. Protective enclosures as outlined under "Planning the Installation" are recommended regardless of checkout frequency.

Location

The mounting location must provide:

- Good, clear access to the field wiring terminals.
- Operating ambient temperatures between -40°F and 175°F (-40°C and 79°C); (165°F [74°C] for S8610 and S8670 models).
- Relative humidity below 95% noncondensing.
- Protection from water, steam or corrosive chemicals that are used to clean the appliance.
- Protection from dripping water, such as from an overfilled humidifier or from condensation.
- Protection from dust or grease accumulation.

Mount the Ignition Module

Select a location close enough to the burner to allow a short (3 ft. [0.9 m] max.), direct cable route to the pilot burner. Ambient temperature at the module must be within the range listed under *Operating Temperature*, on page 2. The module must be protected from water, moisture, corrosive chemicals and excessive dust and grease.

Mount the module with the terminals down to protect them from dripping water and dust. As an alternative, it can also be mounted with the terminals on either side.

IMPORTANT

Do not mount with terminals facing up.

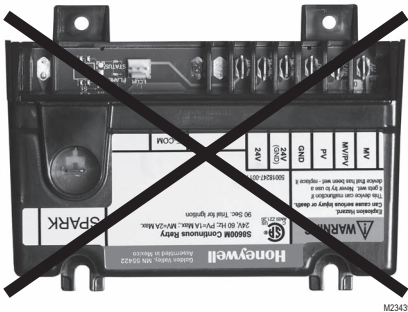

Fig. 1. Incorrect Mounting (Model S8600M shown).

Fasten securely with four No. 6-32 machine or No. 8 sheet metal screws.

Mount the System Controls

Mount any required controls, such as the gas control, spark igniter, flame sensor, thermostat, limit, and transformer according to manufacturer's instructions.

Wire the System

⚠ CAUTION

Equipment Damage Hazard.

Disconnect power supply before beginning wiring or making wiring connections to prevent electrical shock or equipment damage.

All wiring must comply with local codes and ordinances. See Fig. 2 and Table 4 for proper wiring connections.

IMPORTANT

1. As shown in the wiring diagrams, a common ground is required on:
 - a The pilot burner mounting bracket, and
 - b The GND(BURNER) terminal on the ignition module. Failure to use the GND(BURNER) terminal may result in intermittent loss of spark and/or loss of flame current sensitivity.
2. Make sure the transformer has adequate VA. The ignition module requires at least 0.1 A at 24 Vac. Add the current draws of all other devices in the control circuit, including the pilot and main valves in the gas control, and multiply by 24 to determine the total VA requirement of these components. Add this total to 2.4 VA (for the ignition module). The result is the minimum transformer VA rating. Use a Class II transformer if replacement is required.

CONNECT IGNITION CABLE

Use Honeywell ignition cable or construct an ignition cable that conforms to suitable national standards such as Underwriters Laboratories Inc. See Table 2 and Table 3.

Table 2. Honeywell Pre-assembled Ignition Cables (UL Style 3257).

CABLE PART NUMBER	LENGTH	MODULE END	PILOT BURNER
394800-30	30 inches	1/4 inch quick connect, insulated	Rajah connector receptacle, 90 degree rubber boot
394801-30	30 inches	1/4 inch quick connect, insulated	Rajah connector receptacle, straight rubber boot

Table 3. Recommended Ignition Cable for Field Assembly.

CABLE TYPE	VOLTAGE RATING (rms)	TEMPERATURE RATING
UL Style 3217	10,000	302°F (150°C)
UL Style 3257	10,000	484°F (250°C)

Cable must be no longer than 36 in. (0.9 m). To construct a cable, fit one end of ignition cable with 1/4 in. diameter Rajah connector receptacle and the other with a 1/4 in. female quick connect. Protect both ends with insulated boots.

NOTE: The cable must not run in continuous contact with a metal surface or spark voltage will be greatly reduced. Use ceramic or plastic standoff insulators as required.

To install:

- (1) Connect one end of the cable to the male quick connect SPARK terminal on the ignition module.
- (2) Connect the other end of the cable to the igniter or igniter-sensor stud on the pilot burner/igniter-sensor.

CONNECT IGNITION MODULE

NOTE: Refer to Fig. 2 and Table 4 for the location of each connection.

Connect remaining system components to the ignition module terminals as shown in the appropriate wiring diagram.

- Fig. 3 is a basic circuit for the H and M models used in heating systems with atmospheric burners.
- Fig. 4 shows the basic circuit for the B and C models with separate sensor and igniter in a heating system with atmospheric burners.
- Fig. 5—8 show typical circuits for power assisted combustion applications and two-stage gas control with power assisted combustion applications.

MAKE FLAME SENSE CONNECTION

For B, C, J, and K models:

These models have remote flame sensing (two rod). Connect the flame sensor wire from the Pilot burner/igniter to the SENSE connector on the ignition module.

For H, M, D, and E models:

These models have local flame sensing (single rod). The spark lead carries the flame signal.

CONNECT GAS CONTROL

Use 18-gauge solid or stranded wire. Use 1/4 in. female quick connects for module connections. Connect to gas control terminals as shown in wiring diagrams, using terminals appropriate to the gas control.

GROUND CONTROL SYSTEM

The igniter, flame sensor and ignition module must share a common ground with the pilot burner. Use thermoplastic insulated wire with a minimum rating of 221°F (105°C) for the ground wire; asbestos insulation is not acceptable. If necessary, use a shield to protect the wire from radiant heat generated by the burner. Connect the ground wire as follows:

1. Fit one end of the ground wire with a female 1/4 in. quick-connect terminal and connect it to the male quick-connect BRN GND terminal on the ignition module.
2. Strip the other end of the wire and fasten it under the pilot burner bracket mounting screw. If necessary, use a shield to protect the ground wire from radiant heat.
3. The pilot burner serves as the common grounding area. If there is not good metal-to-metal contact between the pilot burner and ground, run a lead from the pilot burner to ground.

NOTE: Earth ground is not required.

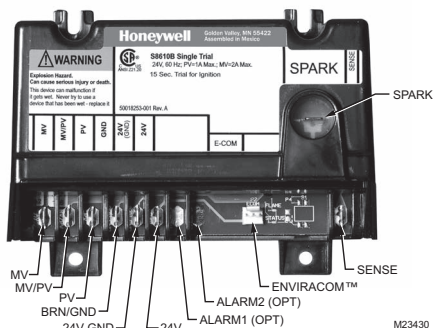

Fig. 2. Ignition Module wiring connection locations (Model S8610B shown).

Table 4. Wiring Connection Descriptions.

Connector Label	Size	Description
MV	1/4 inch	Main Valve connection
MV/PV	1/4 inch	Common terminal for gas valve
PV	1/4 inch	Pilot Valve connection
BRN GND	1/4 inch	Burner Ground
24V GND	1/4 inch	Return path to transformer
24V	1/4 inch	24 Vac ("Call for Heat")
ALARM1	3/16 inch	Alarm connection (optional for B, H, D, and J models only)
ALARM2	3/16 inch	Alarm connection (optional for B, H, D, and J models only)
EnviraCOM™	3-pin	EnviraCOM™ communications connector
SENSE	3/16 inch	Flame Sensor (B, C, J, and K models Only)
SPARK	1/4 inch	High voltage sparking electrode

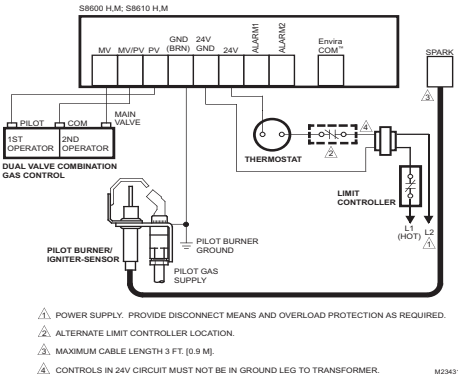

Fig. 3. S8600 H,M; S8610 H,M; connections in a heating system with an atmospheric burner.

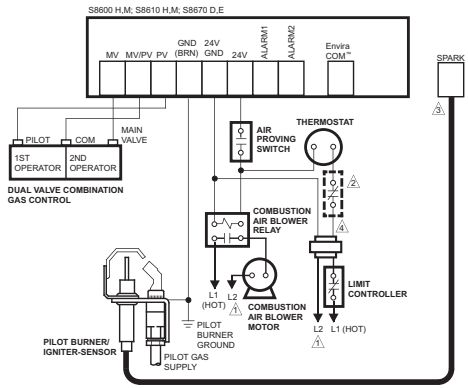

Fig. 5. S8600 H,M; S8610 H,M; S8670 D,E connections in a heating system with power-assisted combustion.

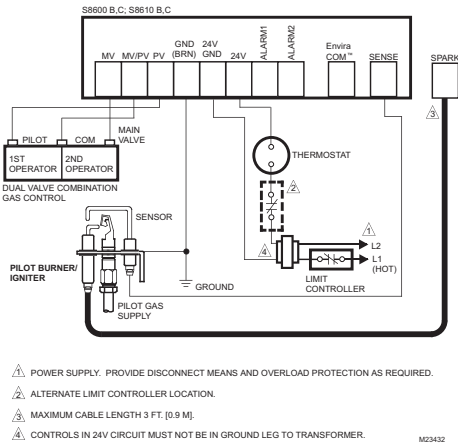

Fig. 4. S8600 B,C; S8610 B,C connections with remote flame sensing in a heating system with an atmospheric burner.

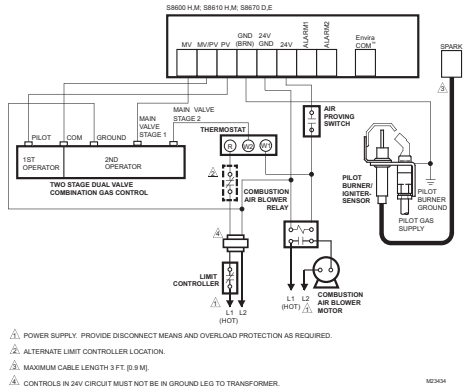

Fig. 6. S8600 H,M; S8610 H,M; S8670 D,E connections in a heating system with a two-stage gas control and power-assisted combustion.

⚠ WARNING

Fire or Explosion Hazard.

Failure to heed these warnings may cause fire or explosion with property damage, injury, or loss of life.

1. If you smell gas or suspect a gas leak, turn off gas at manual service valve and evacuate the building. Do not try to light any appliance, do not touch any electrical switch or telephone in the building until you are sure no spilled gas remains.
2. Gas leak test must be done as described in the steps below on initial installation and any time work is done involving the gas piping.

Step 1: Perform Visual Inspection.

- a. With power off, make sure all wiring connections are clean and tight.
- b. Turn on power to appliance and ignition module.
- c. Open manual shutoff valves in the gas line to the appliance.
- d. Perform Gas Leak Test ahead of gas control if piping has been disturbed.

GAS LEAK TEST:

Paint the gas control gasket edges and all pipe connections upstream of the gas control with a rich soap and water solution. Bubbles indicate gas leaks. Tighten the joints and screws or replace component to stop gas leak. Recheck with soap and water solution.

Step 2: Verify control system ground.

The igniter, flame sensor, and ignition module must share a common ground with the main burner. Use thermoplastic insulated wire with a minimum rating of 221°F (105°C) for the ground wire; asbestos insulation is not acceptable. If the temperature at the wire could exceed 221°F (105°C), use a shield to protect the wire from radiant heat generated by the burner. Connect the ground wire as follows:

- a. Fit one end of the ground wire with a female 1/4 in. quick-connect terminal and connect it to the male quick-connect GND (BURNER) terminal on the ignition module.
- b. Strip the other end of the wire and fasten it under the igniter bracket mounting screw. If necessary, use a shield to protect the ground wire from radiant heat.
- c. The burner serves as the common grounding area. If there is not good metal-to-metal contact between the burner and ground, run a lead from the burner to ground.

NOTE: Earth ground is not required.

Step 3: Review Normal Operating Sequence and Module Specifications.

- a. See "Operation" on page 8 and "Specifications" on page 2.

Step 4: Reset the Module.

- a. Turn the thermostat to its lowest setting.
- b. Wait one minute.

As you do the remaining steps, watch for points where operation deviates from normal. Refer to the Troubleshooting guide on page 15 to correct problems.

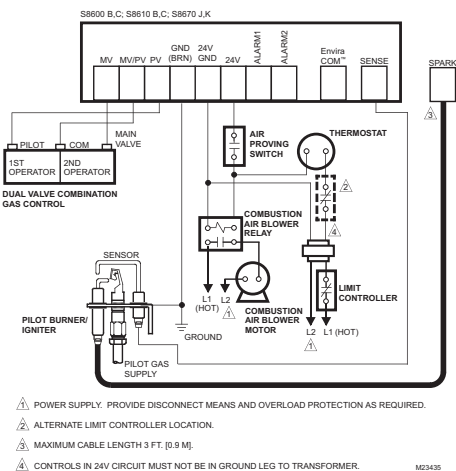

Fig. 7. S8600 B,C; S8610 B,C; S8670 J,K connections with remote flame sensing in a heating system with power-assisted combustion.

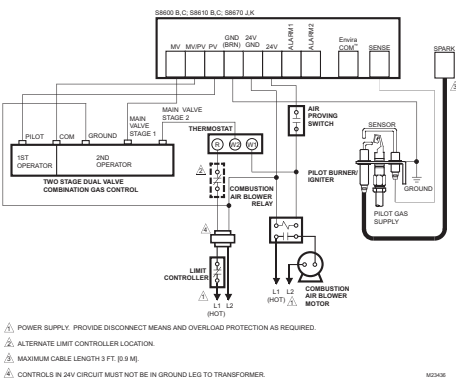

Fig. 8. S8600 B,C; S8610 B,C; S8670 J,K connections with remote flame sensing in a heating system with a two-stage gas control and power-assisted combustion.

CHECKOUT

Check out the gas control system:

- At initial installation of the appliance.
- As part of regular maintenance procedures. Maintenance intervals are determined by the application. See "Planning the Installation" on page 2 for more information.
- As the first step in troubleshooting.
- Any time work is done on the system.

Step 5: Check Safety Shutoff Operation.

- Turn gas supply off.
- Set thermostat or controller above room temperature to call for heat.
- Watch for spark at pilot burner either immediately or following prepurge. See device label.
- Time spark from start to shutoff. See device label.
- On all continuous retry models, wait 5 minutes. Ignition sequence should start again followed by shutoff after 90 seconds maximum.
- Open manual gas cock and make sure no gas is flowing to pilot or main burner.
- Set thermostat below room temperature and wait one minute before continuing.

Step 6: Check Normal Operation.

- Set thermostat or controller above room temperature to call for heat.
- Make sure pilot lights smoothly when gas reaches the pilot burner.
- Make sure main burner lights smoothly without flashback.
- Make sure burner operates smoothly without floating, lifting, or flame rollout to the furnace vestibule or heat buildup in the vestibule.
- Perform a gas leak test in the appliance.

GAS LEAK TEST:

Paint the gas control gasket edges and all pipe connections downstream of the gas control, including the pilot tubing connections, with a rich soap and water solution. Bubbles indicate gas leaks. Tighten the joints and screws or replace component to stop gas leak. Recheck with soap and water solution.

- Turn the thermostat or controller below the room temperature. Make sure the main burner and pilot flames go out.

closes and energizes the S8670. When this model is used in an atmospheric system, the "Call for Heat" energizes the module.

In either case, the module first initiates a 30 second delay to allow system prepurge. After prepurge, the module starts the trial for pilot ignition sequence.

Trial for Pilot Ignition

On a "Call for Heat" (and after prepurge on S8670 models), the module energizes the spark source and the pilot valve relay simultaneously. The pilot valve opens, allowing gas to flow to the pilot burner for the ignition trial time. The spark lights the pilot flame when pilot gas is present. A flame rectification circuit confirms the presence of the pilot flame, shuts off the spark source, and energizes the main valve relay.

The S8600 family uses a two-level pilot flame proving sequence. When a sufficient flame current is sensed, the spark is turned OFF. However, the pilot flame must generate a higher level of flame current to energize the main valve. This approach assures a stable pilot flame to support reliable burner lightoff. If the pilot flame is weak or unstable, the spark may turn back ON. However, the trial for pilot ignition will not exceed the stated ignition trial time

Main Burner Operation

When the main valve opens, gas flows to the main burner where it is lit by the pilot flame. There is a short flame stabilization period as the main valve opens to allow the pilot flame to stabilize as the main gas lights. The system is now in the run mode with the presence of the pilot flame continuously monitored by the flame rectification circuit. If the pilot flame goes out, the control senses loss of pilot flame and shuts off both the pilot valve relay and the main valve relay. Flow of gas to pilot and main burners stops as the valves close.

FAILED TRIAL FOR PILOT IGNITION**Lockout Models—S8600B,H; S8610B,H; S8670D,J**

Lockout models provide a single trial for pilot ignition sequence. If the pilot flame is not lit and sensed before the end of the ignition trial time, the control shuts off the pilot valve (100% shutoff) and goes to lockout. The control remains in lockout until power to the control is cycled by the system thermostat or by removing and restoring system power.

Continuous Retry Models—S8600C,M; S8610C,M; S8670E,J

Continuous retry models provide multiple trials for ignition. If the pilot is not lit or sensed before the end of the trial for ignition time, the control shuts off the spark and pilot gas (100% shutoff). There is a 5 minute delay before another ignition sequence is initiated. The pattern of ignition sequence followed by a 5 minute delay continues until the pilot lights and is proved or the "Call for Heat" ends. The 5 minute delay time can be bypassed by cycling the system thermostat or removing and restoring system power.

OPERATION

Module operation can be conveniently divided into two phases for the S8600 and S8610 and three phases for the S8670.

The phases are:

- Prepurge (S8670 models only)—See Fig. 10
- Trial for ignition (all models)
- Main burner operation (all models)

Fig. 9-10 summarize the normal operating sequences of all the models.

Prepurge (S8670 models Only)

When an S8670 model is used in a fan-assisted combustion system, the combustion air blower starts on a call for heat. On proof of airflow, the air proving switch

OPERATING SEQUENCE - STANDARD MODELS
S8600 C, M; S8610 C, M = RETRY
S8600 B, H; S8610 B, H = LOCKOUT

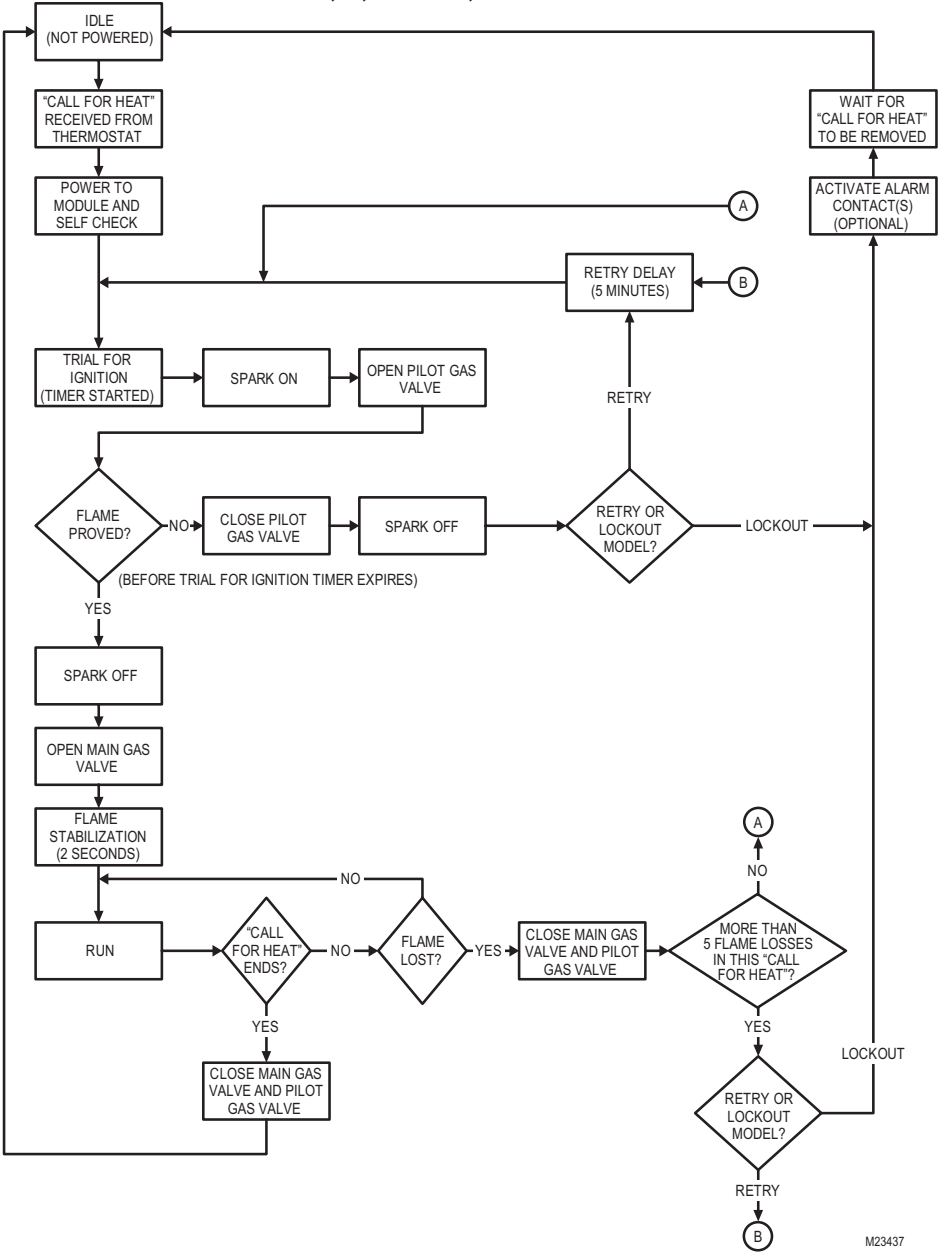
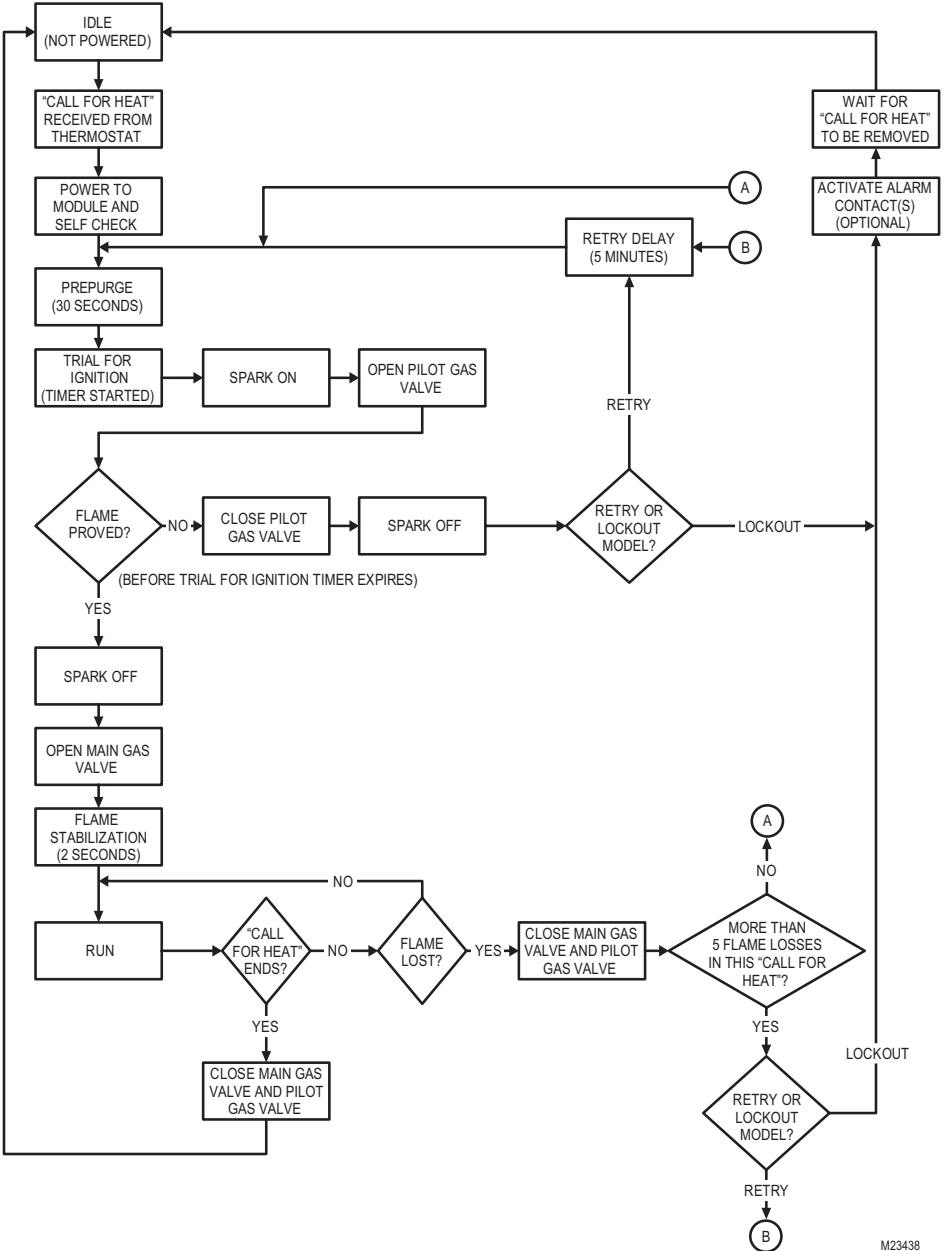

Fig. 9. Normal Operating Sequence for Standard Models.

OPERATING SEQUENCE - PREPURGE MODELS
S8760 E, K = RETRY
S8670 D, J = LOCKOUT



M23438

Fig. 10. Normal Operating Sequence for Prepurge Models.

TROUBLESHOOTING

⚠️ WARNING

Fire, Explosion, or Electrical Shock Hazard.
Can cause severe injury, death or property damage.
 Do not attempt to modify the physical or electrical characteristics of this device in any way. Replace it if troubleshooting indicates a malfunction.

IMPORTANT

1. The following service procedures are provided as a general guide. Follow appliance manufacturer's service instructions if available.
2. Meter readings between the gas control and ignition control must be taken within the trial for ignition period. Once the ignition control shuts off, lockout models must be reset by setting the thermostat down for at least 30 seconds before continuing. On retry models, wait for retry or reset at the thermostat.
3. If any component does not function properly, make sure it is correctly installed and wired before replacing it.
4. The ignition module cannot be repaired. If it malfunctions, it must be replaced.
5. Only trained, experienced service technicians should service intermittent pilot systems.
6. After troubleshooting, check out the system again to be sure it is operating normally.

General troubleshooting process is as follows:

1. Refer to "LED Status and Troubleshooting" on page 12 for LED status codes.
2. Perform the "Checkout" on page 7 as the first step in troubleshooting.
3. Check the troubleshooting guide (Fig. 13) to pinpoint the cause of the problem.
4. If troubleshooting indicates an ignition problem, see Ignition System Checks below to isolate and correct the problem.
5. Following troubleshooting, perform the "Checkout" on page 7 again to be sure system is operating normally.

Ignition System Checks

Step 1: Check ignition cable.

Make sure:

- Ignition cable does not run in contact with any metal surfaces.
- Ignition cable is no more than 36 in. (0.9 m) long.
- Connections to the ignition module and to the igniter or igniter-sensor are clean and tight.
- Ignition cable provides good electrical continuity.

STEP 2: Check ignition system grounding.

Nuisance shutdowns are often caused by a poor or erratic ground.

A common ground is required for the module and the pilot burner bracket.

- Check the ground circuit from the GND(BURNER) terminal on the module to the pilot burner. Make sure connections are clean and tight. If the wire is damaged or deteriorated, replace it with 14- to 18-gauge, moisture-resistant, thermoplastic insulated wire with 221°F (105°C) minimum rating.
 - If the flame rod or bracket is bent out of position, restore to correct position.

STEP 3: Check spark ignition circuit. You will need a short jumper wire made from ignition cable or other heavily insulated wire.

- Close the manual gas valve.
- Disconnect the ignition cable at the SPARK terminal on the module.

⚠️ WARNING

Electrical Shock Hazard.

Can cause severe injury, death or property damage.
 When performing the following steps, do not touch stripped end of jumper or SPARK terminal. The ignition circuit generates over 10,000 volts and electrical shock can result.

- Energize the module and immediately touch one end of the jumper firmly to the GND terminal on the module. Move the free end of the jumper slowly toward the SPARK terminal until a spark is established.
- Pull the jumper slowly away from the terminal and note the length of the gap when sparking stops. Check Table 5 below.

Table 5. Arc Troubleshooting.

Arc Length	Action
No arc or arc less than 1/8 in. (3 mm)	Check external fuse, if provided. Verify power at the module's input terminal. Replace control if fuse and power are okay.
Arc 1/8 in.(3 mm) or longer	Voltage output is okay.

STEP 4: Check pilot and main burner lightoff.

- Set the thermostat to call for heat.
- Watch the pilot burner during the ignition sequence. See if:
 - Ignition spark continues after the pilot is lit.
 - The pilot lights and the spark stops, but main burner does not light.
 - S8600 B,H; S8610 B,H; S8670 D,J only: The pilot lights, the spark stops and main burner lights, but the system shuts down.
- If so, ensure adequate flame current as follows.
 - Turn off furnace at circuit breaker or fuse box.
 - Clean the flame rod with emery cloth.
 - Make sure electrical connections are clean and tight. Replace damaged wire with moisture-resistant No. 18 wire rated for continuous duty up to 221°F (105°C).
 - Check for cracked ceramic insulator, which can cause short to ground, and replace igniter-sensor if necessary.
 - At the gas control, disconnect main valve wire from the MV terminal.

- Turn on power and set thermostat to call for heat. The pilot should light but the main burner will remain off because the main valve actuator is disconnected.
- Check the pilot flame. Make sure it is blue, steady and envelops 3/8 to 1/2 in. (10 to 13 mm) of the flame rod. See Fig. 11 for possible flame problems and their causes.
- If necessary, adjust pilot flame by turning the pilot adjustment screw on the gas control clockwise to decrease or counterclockwise to increase pilot flame. Following adjustment, always replace pilot adjustment cover screw and tighten firmly to assure proper gas control operation.
- Set thermostat below room temperature to end call for heat.





APPEARANCE	CAUSE
<p>SMALL BLUE FLAME</p> 	<p>CHECK FOR LACK OF GAS FROM:</p> <ul style="list-style-type: none"> • CLOGGED ORIFICE FILTER • CLOGGED PILOT FILTER • LOW GAS SUPPLY PRESSURE • PILOT ADJUSTMENT AT MINIMUM
<p>LAZY UPRIGHT FLAME</p> 	<p>CHECK FOR LACK OF AIR FROM:</p> <ul style="list-style-type: none"> • DIRTY ORIFICE • DIRTY LINT SCREEN, IF USED • DIRTY PRIMARY AIR OPENING, IF THERE IS ONE • PILOT ADJUSTMENT AT MINIMUM
<p>WAVING BLUE FLAME</p> 	<p>CHECK FOR:</p> <ul style="list-style-type: none"> • EXCESSIVE DRAFT AT PILOT LOCATION • RECIRCULATING PRODUCTS OF COMBUSTION
<p>NOISY LIFTING BLOWING FLAME</p> 	<p>CHECK FOR:</p> <ul style="list-style-type: none"> • HIGH GAS PRESSURE
<p>HARD SHARP FLAME</p> 	<p>THIS FLAME IS CHARACTERISTIC OF MANUFACTURED GAS</p> <p>CHECK FOR:</p> <ul style="list-style-type: none"> • HIGH GAS PRESSURE • ORIFICE TOO SMALL

Fig. 11. Examples of unsatisfactory pilot flames.

- Recheck ignition sequence as follows.
 - Reconnect main valve wire.
 - Set thermostat to call for heat.
 - Watch ignition sequence at burner.
 - If spark still doesn't stop after pilot lights, replace ignition control.
 - If main burner doesn't light or if main burner lights but system locks out, check the control, ground wire and gas control as described in "Troubleshooting" on page 11 and refer to the Troubleshooting Guide (Fig. 13).

LED Status and Troubleshooting

The control has two LEDs; one for flame sensing and one for system status:

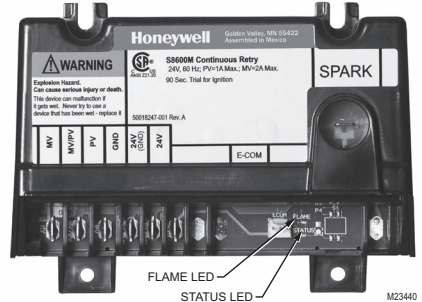

Fig. 12. Location of LEDs.

- **Flame LED (Yellow)**
 - Indicates flame presence and strength. See Table 6.
- **Status LED (Green)**
 - Indicates system operation status and error conditions. See Table 7 and Table 8 for status specific to each model.

Table 6. Yellow LED Flame Codes.

Yellow LED Flash Code ^a	Indicates	Recommended Service Action
Heartbeat	Normal Flame Signal	Not applicable
2	Weak Flame Signal— System will operate reliably but flame signal is less than desired. NOTE: This indication may flash temporarily during or shortly after lightoff on some applications.	Perform routine maintenance to assure optimum flame signal.
1	Marginal Flame Signal (less than 1.1µA)— System may not operate reliably over time. Service call recommended. NOTE: This indication may flash temporarily during or shortly after lightoff on some applications.	Check gas supply, pilot burner, flame sense wiring, contamination of flame rod, burner ground connection.
OFF	No Flame or Flame Signal below minimum threshold for system operation.	Not applicable

^a Flash Code Descriptions:

- Heartbeat: Constant ½ second bright, ½ second dim cycles.
- The flash code number signifies that the LED flashes X times at 2Hz, remains off for two seconds, and then repeats the sequence.

Table 7. Continuous Retry Models C, M, E, and K Only—Green LED Status Codes.

Green LED Flash Code (X + Y) ^a	Indicates	Next System Action	Recommended Service Action
OFF	No "Call for Heat"	Not applicable	None
Flash Fast	Startup - Flame sense calibration	Not applicable	None
Heartbeat	Normal operation	Not applicable	None
2	5 minute Retry Delay - Pilot flame not detected during trial for ignition	Initiate new trial for ignition after retry delay completed.	If system fails to light on next trial for ignition check gas supply, pilot burner, spark and flame sense wiring, flame rod contaminated or out of position, burner ground connection.
3	Recycle - Flame failed during run	Initiate new trial for ignition. Flash code will remain through the ignition trial until flame is proved.	If system fails to light on next trial for ignition, check gas supply, pilot burner, flame sense wiring, contamination of flame rod, burner ground connection.
4	Flame sensed out of sequence	If situation self corrects within 10 seconds, control returns to normal sequence. If flame out of sequence remains longer than 10 seconds, control goes to Flash code 6+4 (see below).	Check for pilot flame. Replace gas valve if pilot flame present. If no pilot flame, cycle "Call for Heat." If error repeats, replace control.
7	Flame sense leakage to ground	Control remains in wait mode. When the fault corrects, control resumes normal operation after a one minute delay.	Check flame sense lead wire for damage or shorting. Check that flame rod is in proper position. Check flame rod ceramic for cracks, damage or tracking.
8	Low secondary voltage supply - (below 15.5 Vac)	Control remains in wait mode. When the fault corrects, control resumes normal operation after a one minute delay.	Check transformer and AC line for proper input voltage to the control. Check with full system load on the transformer.
6+2	5 minute Retry Delay - On every third retry on the same "Call for Heat"	Initiate new trial for ignition after retry delay completed.	Check gas supply, pilot burner, spark and flame sense wiring, flame rod contaminated or out of position, burner ground connection.
6+3	On every 6th flame failure during run on the same "Call for Heat"	5 minute retry delay, then initiate new trial for ignition.	Check gas supply, pilot burner, flame sense wiring, contamination of flame rod, burner ground connection.
6+4	Flame sensed out of sequence - longer than 10 seconds	Control waits until flame is no longer sensed and then goes to soft lockout. Flash code continues. Control auto resets from soft lockout after one hour.	Check for pilot flame. Replace gas valve if pilot flame present. If no pilot flame, cycle "Call for Heat." If error repeats, replace control.
ON	Soft lockout due to error detected during self check sequences	Control auto resets from soft lockout after one hour.	Reset by cycling "Call for Heat." If error repeats, replace the control.

^a Flash Code Descriptions:

- Flash Fast: rapid blinking.
- Heartbeat: Constant ½ second bright, ½ second dim cycles.
- A single flash code number signifies that the LED flashes X times at 2Hz, remains off for two seconds, and then repeats the sequence.
- X + Y flash codes signify that the LED flashes X times at 2Hz, remains off for two seconds, flashes Y times at 2Hz, remains off for three seconds, and then repeats the sequence.

Table 8. Lockout Models B, H D, and J Only—Green LED Status Codes.

Green LED Flash Code (X + Y)^a	Indicates	Next System Action	Recommended Service Action
OFF	No "Call for Heat"	Not applicable	None
Flash Fast	Startup - Flame sense calibration	Not applicable	None
Heartbeat	Normal operation	Not applicable	None
3	Recycle - Flame failed during run	Initiate new trial for ignition. Flash code will remain through the ignition trial until flame is proved.	If system fails to light on next trial for ignition, check gas supply, pilot burner, flame sense wiring, contamination of flame rod, burner ground connection.
4	Flame sensed out of sequence	If situation self corrects within 10 seconds, control returns to normal sequence. If flame out of sequence remains longer than 10 seconds, control goes to Flash code 6+4 (see below).	Check for pilot flame. Replace gas valve if pilot flame present. If no pilot flame, cycle "Call for Heat." If error repeats, replace control.
7	Flame sense leakage to ground	Control remains in wait mode. When the fault corrects, control resumes normal operation after a one minute delay.	Check flame sense lead wire for damage or shorting. Check that flame rod is in proper position. Check flame rod ceramic for cracks, damage or tracking.
8	Low secondary voltage supply - (below 15.5 Vac)	Control remains in wait mode. When the fault corrects, control resumes normal operation after a one minute delay.	Check transformer and AC line for proper input voltage to the control. Check with full system load on the transformer.
6+2	Failed trial for ignition resulting in lockout	Remain in lockout until "Call for Heat" is cycled.	Check gas supply, pilot burner, spark and flame sense wiring, flame rod contaminated or out of position, burner ground connection.
6+3	More than 5 flame failures during run on the same "Call for Heat" resulting in lockout	Remain in lockout until "Call for Heat" is cycled.	Check gas supply, pilot burner, flame sense wiring, contamination of flame rod, burner ground connection.
6+4	Flame sensed out of sequence - longer than 10 seconds	Control waits until flame is no longer sensed and then goes to soft lockout. Flash code continues. Control auto resets from soft lockout after one hour.	Check for pilot flame. Replace gas valve if pilot flame present. If no pilot flame, cycle "Call for Heat." If error repeats, replace control.
ON	Soft lockout due to error detected during self check sequences	Control auto resets from soft lockout after one hour.	Reset by cycling "Call for Heat." If error repeats, replace the control.

^a Flash Code Descriptions:

- Flash Fast: rapid blinking.
- Heartbeat: Constant ½ second bright, ½ second dim cycles.
- A single flash code number signifies that the LED flashes X times at 2Hz, remains off for two seconds, and then repeats the sequence.
- X + Y flash codes signify that the LED flashes X times at 2Hz, remains off for two seconds, flashes Y times at 2Hz, remains off for three seconds, and then repeats the sequence.

Troubleshooting Guide

Refer to the following guide for troubleshooting (Fig. 13).

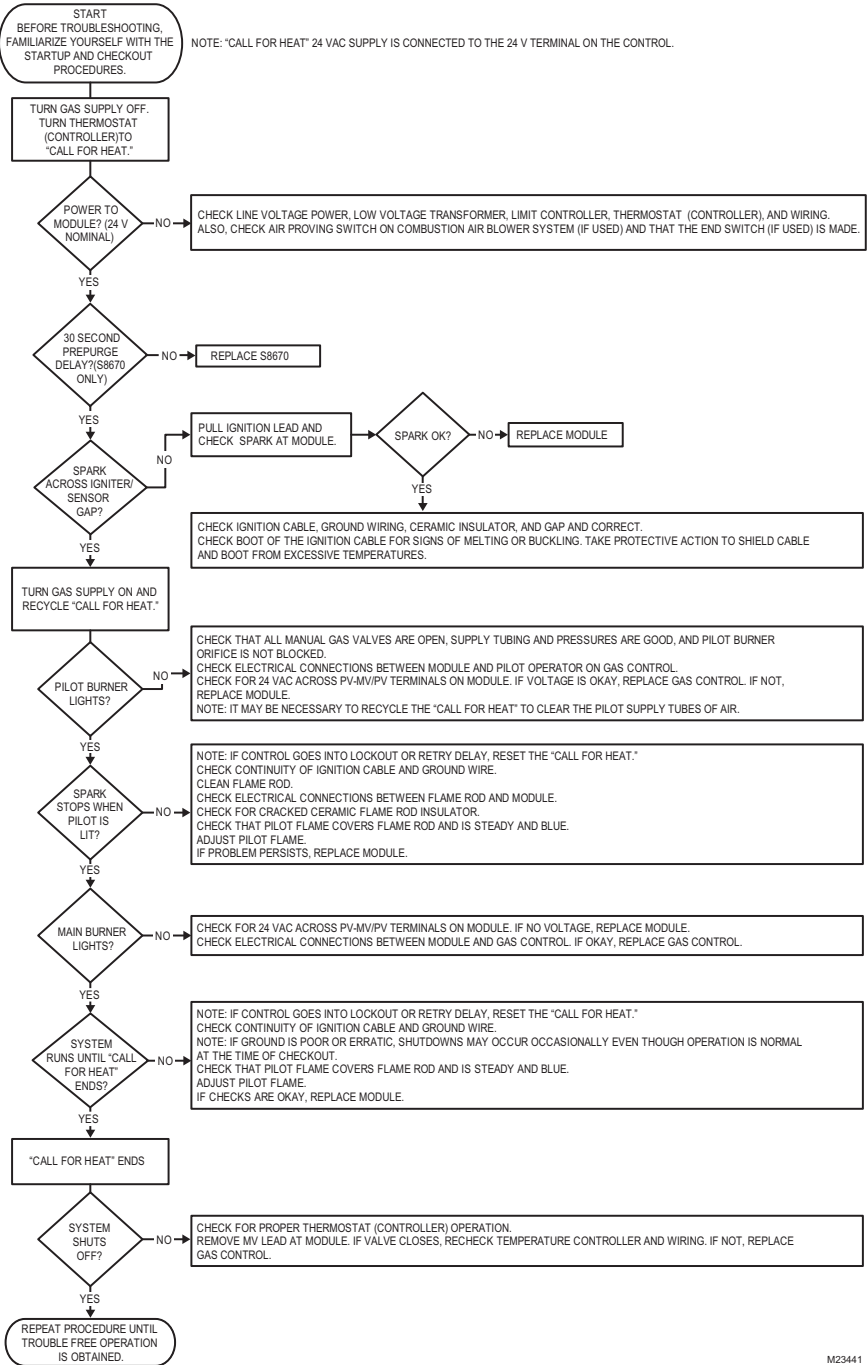

M23441

Fig. 13. Troubleshooting Guide.

Automation and Control Solutions

Honeywell International Inc.
1985 Douglas Drive North
Golden Valley, MN 55422
customer.honeywell.com

Honeywell Limited-Honeywell Limitée
35 Dynamic Drive
Toronto, Ontario M1V 4Z9

Honeywell

® U.S. Registered Trademark
© 2006 Honeywell International Inc.
69-1954 M.S. 06-06



Printed in U.S.A. on recycled
paper containing at least 10%
post-consumer paper fibers.